

FICHE D,HOMOLOGATION HOMOLOGATION FORM



COMMISSION INTERNATIONALE
DE KARTING - FIA



SILENCIEUX D,ASPIRATION / INTAKE SILENCER

Constructeur	<i>Manufacturer</i>	Righetti Ridolfi
Marque	<i>Make</i>	Righetti Ridolfi
Modèle	<i>Model</i>	NOX2-30
Catégories	<i>Categories</i>	KZ & KZ2
Durée de l'homologation	<i>Validity of the homologation</i>	3 ans / 3 years
Nombre de pages	<i>Number of pages</i>	5

La présente Fiche d'Homologation reproduit descriptions, illustrations et dimensions du silencieux d'aspiration au moment de l'homologation CIK-FIA et du test d'homologation.

This Homologation Form reproduces descriptions, illustrations and dimensions of the intake silencer at the moment of the CIK-FIA homologation and of the homologation test.



PHOTO DE L'AVANT /
PHOTO OF THE FRONT

PHOTO DE CÔTÉ /
PHOTO OF THE SIDE

Signature et tampon de l,ASN /
Signature and stamp of the ASN

Signature et tampon de la CIK-FIA /
Signature and stamp of the CIK-FIA



V. Aluade



A	DESCRIPTIONS TECHNIQUES	A	TECHNICAL DESCRIPTIONS
	Volume en cm ³	Volume in cc	3660 cm ³ +/-2%
	Matériau	Material	PP
	Nombre d'ouvertures d'admission d'air	Number of air intake openings	2
	Longueur des conduits d'admission	Length of the inlet ducts	100 mm +/-2% (≥98mm)
	Diamètre des conduits d'admission	Diameter of the inlet ducts	30 mm max.
	Surface de l'élément filtrant intérieur	Surface of the internal filter	253 cm ² +/-2% (≥200cm ²)
	Epaisseur de l'élément filtrant	Thickness of the internal filter	30 mm -10%

A1	DESSIN TECHNIQUE [dimensions d'encombrement – diamètre du (des) tube(s) d'admission – diamètre de la fixation au carburateur, sans tolérances]	A1	TECHNICAL DRAWING [main external dimensions – diameter of the inlet tube(s) – diameter of the fixation to the carburettor, without tolerances]
----	---	----	---

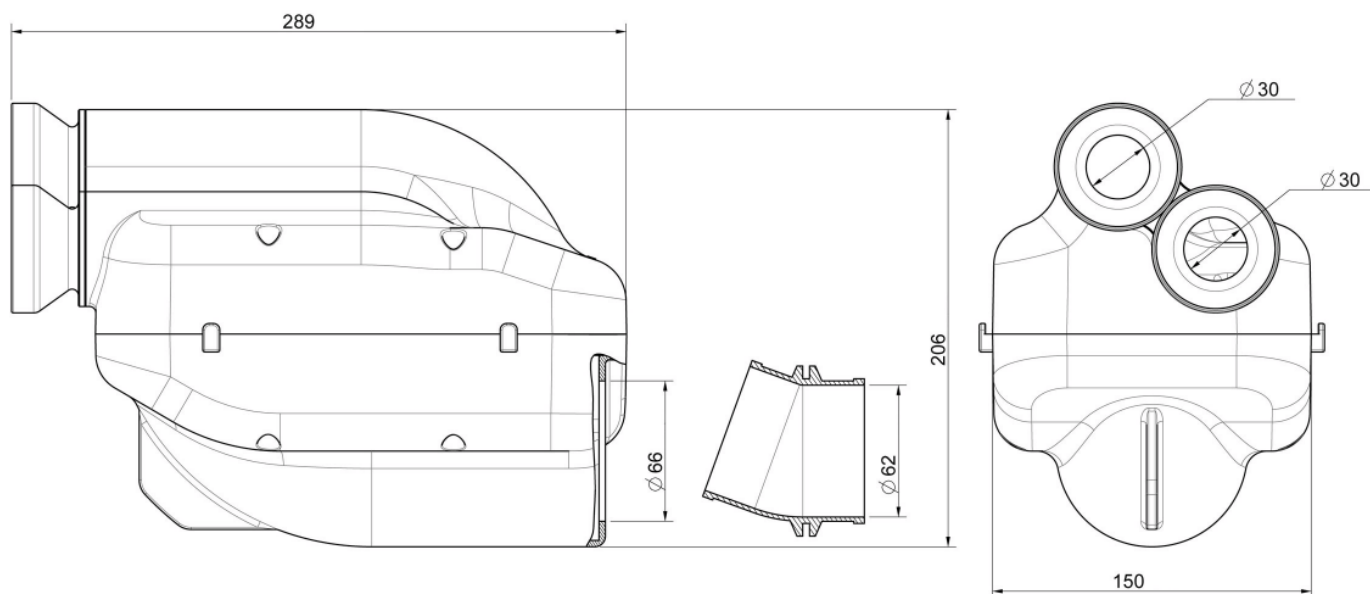

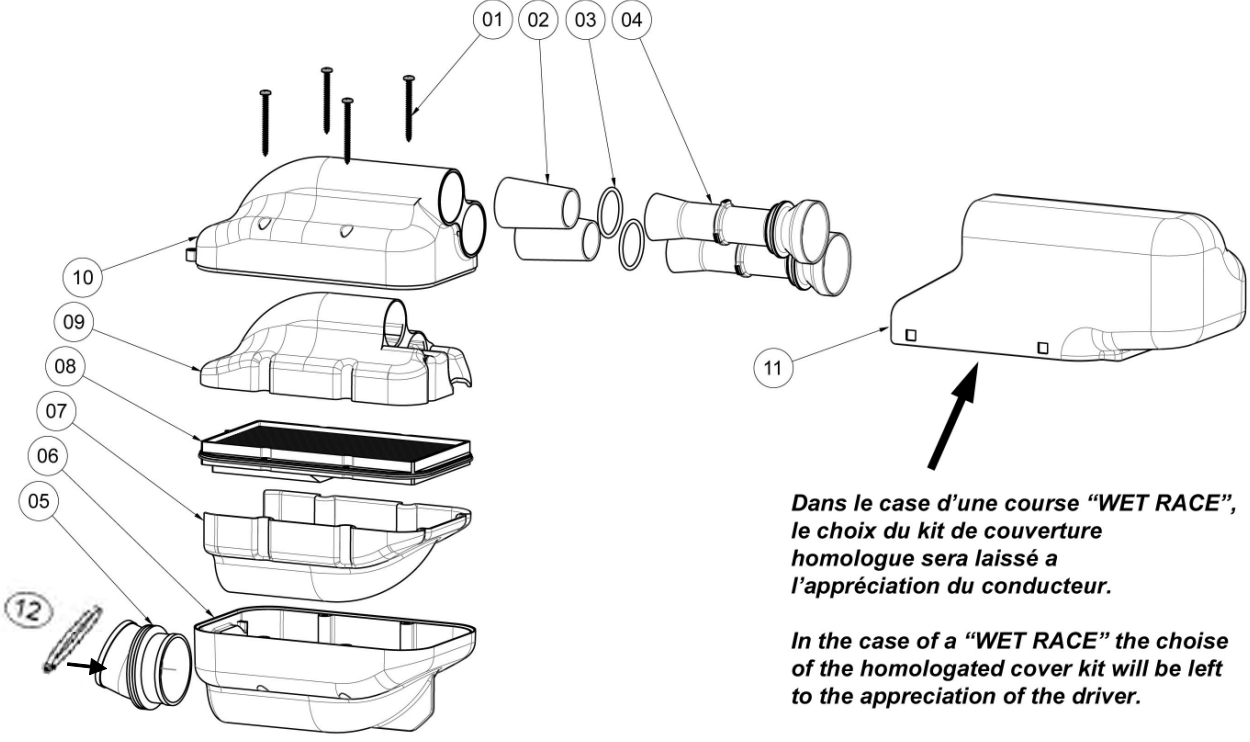
A2	DESSIN TECHNIQUE EXPLODÉ	A2	EXPLODED TECHNICAL DRAWING
 <p data-bbox="933 788 1385 898"><i>Dans le case d'une course "WET RACE", le choix du kit de couverture homologue sera laissé a l'appréciation du conducteur.</i></p> <p data-bbox="933 927 1374 1010"><i>In the case of a "WET RACE" the choise of the homologated cover kit will be left to the appreciation of the driver.</i></p>			
<p data-bbox="92 1131 1520 1193">Le dessin technique explosé doit montrer : Eléments du silencieux, éléments acoustiques absorbants, éléments filtrants, tubes d'aspiration et manchon de fixation au carburateur.</p> <p data-bbox="103 1193 1513 1252">The exploded technical drawing must show the following: parts of the silencer, noise-absorbing parts, filtering parts, suction tubes and carburettor clamping sleeve.</p>			

N°	DÉSIGNATION	DESIGNATION	Référence catalogue / Catalogue reference number
01	Vis D.5x60	Screw D.5x60	KVP05060S
02	Bande adhésive insonorisante tube 30	Ahesive soundproof band - 30 tube	KE072-T30N
03	O-Ring	O-Ring	KE067
04	Tubes d'Aspiration D.30mm	Suction Tubes D.30mm	KE066
05	Raccord en caoutchouc	Rubber Connector	K070
06	Corps filtre inferieur	Lower side body filter	ZZKE060B
07	Internes barriere acustique inferieur	Lower internal acoustic barrier	■■■■-INF
08	Cartouche filtre	Air filter cartridge	KE075
09	Internes barriere acustique superieur	Upper internal acoustic barrier	KE062
10	Corps filtre supérieur	Upper body filter	ZZKE060A
11	Protection Pluie	Rain Cover	KE090
12	Serre-joint en métal	Metal screw clamp	KE088
	L'élément N.10 peut être tourné à 180°	The element N.10 can be rotated 180°	

A3	PHOTO DU MARQUAGE ET NUMÉRO D'HOMOLOGATION	A3	PHOTO OF MARKING AND HOMOLOGATION NUMBER
-----------	---	-----------	---



Le Marquage et le Numéro d'Homologation doivent rester clairement visibles en permanence. / The marking and the homologation number must remain clearly visible permanently.

A4	PHOTO DU FILTRANT	A4	PHOTO OF THE FILTER
-----------	--------------------------	-----------	----------------------------



Photo du filtrant complet vu du haut et cote / Photo of the filter from above and from the side.